



Wood Stand Instructions

For making a wood stand to be used by Mitchell Wreaths™ machines (No-Hammer™, Craftmaster™ or Original™)

The Hardware Pack is Not included with the Machine.

Available for purchase, see below for contact info.

Included in the Part# 589764 the **Hardware Pack**:

- A] Angle Brackets; quantity Eight(8).
- B] Carriage Bolts, 3½ x ¼ inch; quantity Sixteen(16).
- C] Carriage Bolts, 2 x ¼ inch; quantity Twenty(20).
- D] Lock Washers, ¼ inch; quantity ThirtySix(36).
- E] Hex Nut, ¼ inch by 20; quantity ThirtySix(36).
- F] Flat Washers, ¼ inch; quantity Four(4).
- G] Deck Screws, 2½ inch; quantity TwentyTwo(22).
- H] Deck Screws, 1 inch; quantity Fourteen(14).

Equipment will **you need**:

- A] Table Saw or Chop Saw or Miter Saw if you need to cut the wood, most stores can do this for a fee.
- B] Drill and Jig Saw or small hand saw, for Table Top.
- C] A 5/16 inch Drill Bit for the Carriage Bolt holes.
- D] A 7/16 inch Box Wrench, Socket or Adjustable Wrench.
- E] Standard and Phillips screw drivers, average sized.

Additional supplies you will **need**:

A] Standard 2x4; 6 footers, quantity Five(5).

Either cut or have them cut into below -or-

x] 2x4; length of **35** inches; quantity **Four(4)**.

y] 2x4; length of **24** inches; quantity **Three(3)**.

z] 2x4; length of **21** inches; quantity **Five(5)**.

If you wish to cut the boards, cut them as follows:

6' Board 1; you can get 2@35".

6' Board 2; you can get 2@35".

6' Board 3; you can get 2@24" and 1@21".

6' Board 4; you can get 1@24" and 2@21".

6' Board 5; you can get 2@21".

B] Plywood 3/8 inches thick, 2 feet by 2 feet square.

See the instructions for more specifics on cutting the machine opening in (Step7).

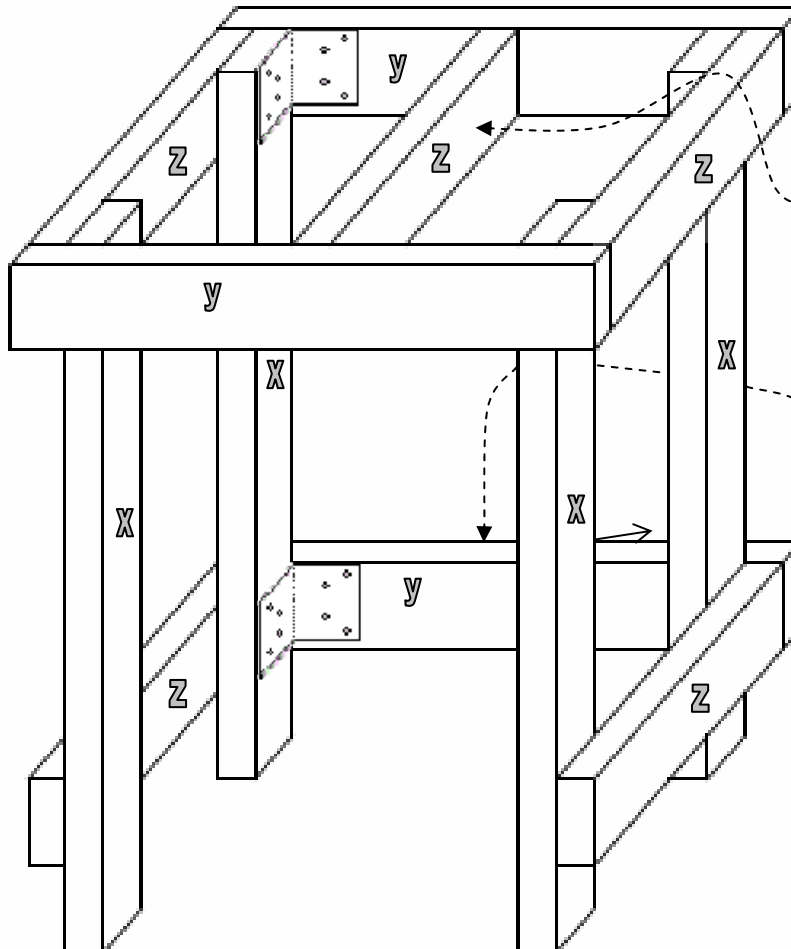

This is the Center Board, and will need to be pre-drilled specifically for the machine type that will be installed (No-Hammer™, Craftmaster™ or Original™).

Which ever machine is used the foot pedal will be in the same location, on this frame the Center hole for the foot pedal will be located at the 12" mark, from either side.

Seven Detailed Step by Step Instructions to follow.



Wood Stand Instructions

For making a wood stand to be used by Mitchell Wreaths™ machines (No-Hammer™, Craftmaster™ or Original™)

Step 1: Cut the frame boards.

You will need the following boards.

- x] 2x4; length of **35** inches; quantity **Four(4)**.
- y] 2x4; length of **24** inches; quantity **Three(3)**.
- z] 2x4; length of **21** inches; quantity **Five(5)**.

**Be sure that you get boards that are as straight as possible!
Don't use particle board; the stronger the wood
the stronger and more durable the stand!**

This can be done from the suggested 4@6 foot length and 1@4 foot length, as follows:

- 6' Board 1; you can get 2@35".
- 6' Board 2; you can get 2@35".
- 6' Board 3; you can get 2@24" and 1@21".
- 6' Board 4; you can get 1@24" and 2@21".
- 4' Board 1; you can get 2@21".

This can be done from 3@8 foot length and 1@4 foot length, as follows:

- 8' Board 1; you can get 2@35" and 1@24".
- 8' Board 2; you can get 2@35" and 1@24".
- 8' Board 3; you can get 1@24" and 3@21".
- 4' Board 1; you can get 2@21".

Or you might have some extra on hand and can make the required boards.

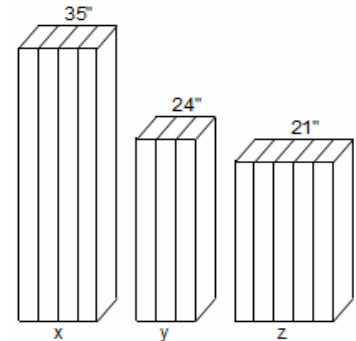

Step 2: Assemble the top of the Table Frame.

You will need the following boards.

- y] 2x4; length of **24** inches; quantity **Two(2)** of the Three(3).
- z] 2x4; length of **21** inches; quantity **Two(2)** of the Five(5).

- > Drill a pilot hole first to keep from splitting the wood, Don't place them right in the center, stagger them. Use **4@2½" Decking Screws**; one on each corner. These will be used to tack them into place and further strengthened by the Angle Brackets.

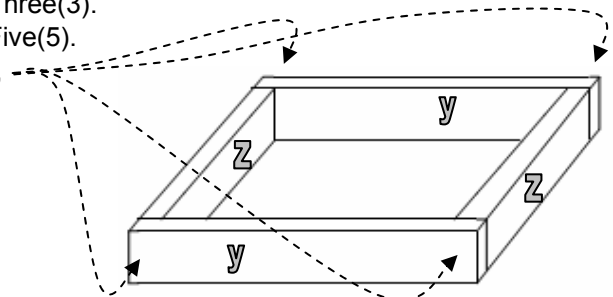

Staggered means offset; see this **Example:** Keep in mind the bracket will be drilled and another board will be tacked in step 3.

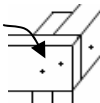

Step 3: Attach the legs to the Top Table Frame.

You will need the following boards.

- x] 2x4; length of **35** inches; quantity all **Four(4)** of Four(4).

- > Drill a pilot hole first to keep from splitting the wood, Don't place them right in the center, just a little lower. Be sure that the tops of the legs are flush with the top. Use **8@2½" Decking Screws**; tack one on each corner.

See "Step 2 example" for placement of screws.

- > Now you will need to install the **Angle Brackets** that is **Four(4)** of the Eight(8). They will attach to each leg both the front and back boards. Hold them in place (being sure that they are flush with the top) mark them with a pencil, then drill the holes for the Carriage Bolts.
- > Use **8@3½" Carriage Bolts**; two on each Double 2x4 side. and Use **8@2" Carriage Bolts**; two on each Single 2x4 side. you will also use the Lock Washers and Hex Nut for each bolt.

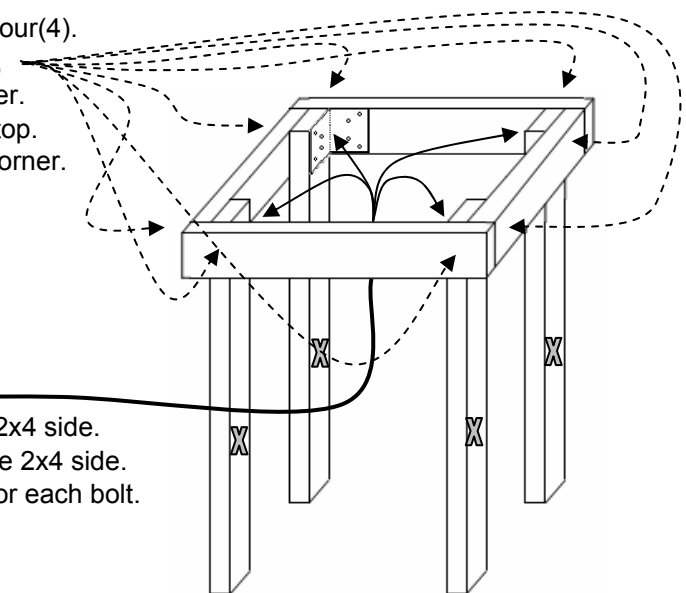

Use the two inside most holes from each side.

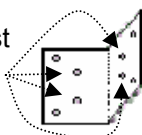



Wood Stand Instructions

For making a wood stand to be used by Mitchell Wreaths™ machines (No-Hammer™, Craftmaster™ or Original™)

Step 4: Attach the Bottom Frame Pieces.

You will need the following boards.

y] 2x4; length of **24** inches; quantity **One(1)** of the Three(3).

z] 2x4; length of **21** inches; quantity **Two(2)** of the Five(5).

> Use **2@2½ Decking Screws** to tack the two side boards to the back board; again staggered like in step 2.

> Use some of the scrap wood to set the level temporarily, of the bottom assembly approximately 1½" then use more **6@2½" Decking Screws** to tack that bottom assembly to the frame.

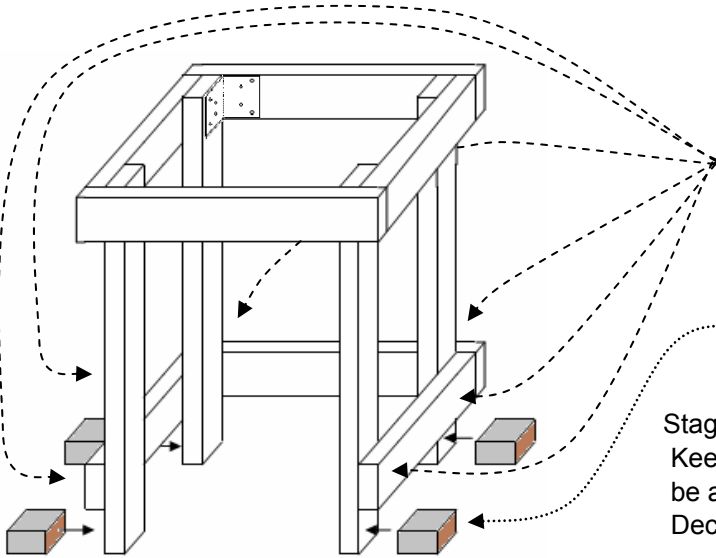
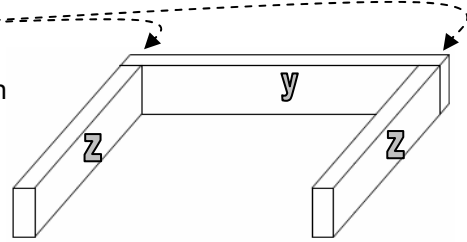

Apply the Six(6) Decking Screws here to tack the bottom assembly to the Frame. Again the back Two(2) will be staggered and the side Four(4) will be centered in the board.

These four pieces of Scrap 2x4 wood; are remnants from Step 1, length doesn't matter.

Staggered means offset; see this **Example:** Keep in mind that the Angle Brackets will be attached in Step 5 and the bolts and Deck Screws need to be clear of each other.

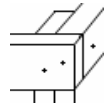

Step 5: Attach the Bottom Frame Pieces.

> Hold the brackets in place and mark then drill the holes. Keep in mind use the inside holes like in step 3 above. You will use only **two** of the remaining **Angle Brackets** for the back of the Frame. Use **8@3½" Carriage Bolts**; two on each Double 2x4 side and use **4@2" Carriage Bolts** 2 on the Single 2x4 sides. You will also need **4@ Flat Washers** and **4@2" Carriage Bolts** for the front legs. Again, with the appropriate Lock Washers and Hex Nuts per each Carriage Bolt being used. They should be staggered to keep the wood from splitting.

> The outside smooth edge of the all the Carriage bolts should be on the outside of the Stand with the Lock Washers and Nuts on the inside of the Frame to help eliminate abrasions during use, due to close proximity.

Example of staggered bolts to help keep the wood from splitting during use. For front leg pieces.

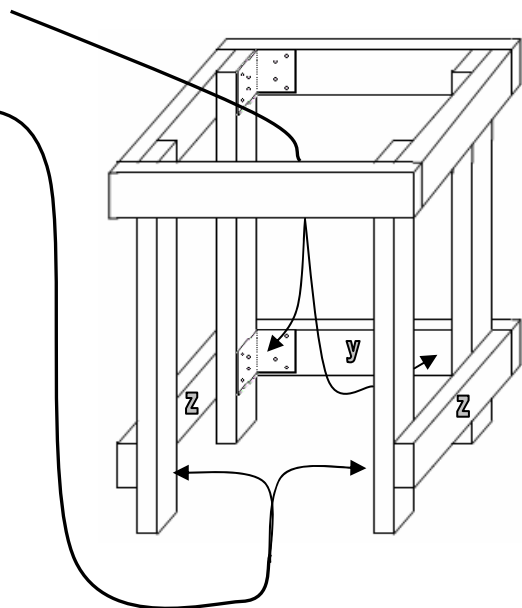
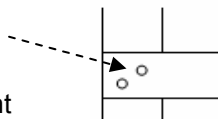



Wood Stand Instructions

For making a wood stand to be used by Mitchell Wreaths™ machines (No-Hammer™, Craftmaster™ or Original™)

Step 6: Prepare and Attach the Center Board

You will need the following board.

Z] 2x4; length of **21** inches; quantity **One(1)** of the Five(5).

- > Place the Hole Drilling Template on the Center Board and with a Phillips Screwdriver press marks on the appropriate holes that are needed depending on the machine that is being installed. Follow the instructions on the Template as it might have additional comments which are machine dependant. Also, place the board on the frame and hold the Angle Brackets in place and mark those holes too. Keep in mind that the brackets should be flush with the top of the Wood Stand Frame. Also keep in mind that the only time you will need to use the holes on the outside of the Angle Bracket is when it is at the back of the Frame Board and you will be using a No-Hammer™ machine. These additional holes will be used for the back of the Machine where it is connected with the Foot Pedal Arm.
- > Once the holes are marked, drill holes for the machine on the Center Board and tack it in place with **2@2" Decking Screws** one on the front, one on the back both Centered. And attach the **8@2" Carriage Bolts** and Lock Washers and Hex Nuts.
- > Location for the last **two Angle Brackets**.
- > Don't worry if the No-Hammer™ machine is mounted higher than the top of the Center Board, this is needed to be sure that it has sufficient clearance with the Table Top. Also the Original™ will be lower than the Center Board.
- > When the Center Board is mounted be sure that it is 10" from the Outside edge of the Left Top Frame Board.
- > Adjust the fool pedal, that during normal operation the foot pedal bottoms out on the floor; to protect machine.

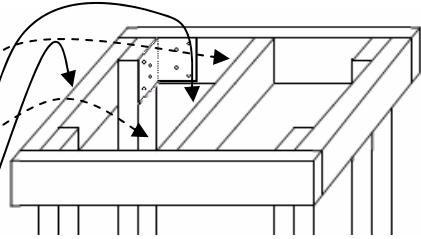

Picture shows Original™ Installed and a No-Hammer™ with a separate Center Board for the purpose of showing the back part.

Step 7: Prepare the Table Top and Install it.

You will need the following board.

B] Plywood $\frac{3}{8}$ inches thick, 2 feet by 2 feet square.

- > Drill the holes for the cut out section. The size of the drill bit is not critical, but make sure that it is large enough for the jigsaw to cut out the rest of the section.
- > Before using the **14@1" Decking Screws** to fasten the top to the Frame place it on the top and visually inspect that the machine is lined up correctly for operation. Make adjustments then secure the top in place.

- > Decking Screw Placement pattern, secures the top.

